

4.0
READY

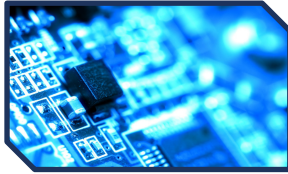

SI-STAR

Sinergo
top class
desktop
soldering
robot



SI-PRO
soldering station

SI-STAR
desktop soldering robot

SISMART
medium size soldering robot

SINAX
"big size" soldering robot

SIRTAS
*rotating table - pallet line
multihead soldering machines*

SI-STAR Sinergo desktop soldering robot



MAIN FEATURES

Four axes
working area X 300 Y 240 Z 120 R 330°

MECHANICS

Top class design & construction.
high speed high precision movements
recirculating balls screws and guides

ELECTRONICS

Stepper motors and digital drives
PLC motion controller on board.

SAFETY

“Safety chain circuit inside”
Connector to integrate SI-STAR as per CE norms

EPA ESD

Materials, paints, construction, ... compliant

HUMAN MACHINE INTERFACE

Sinergo software for Windows 7-10

ELECTRIC INTERFACE

to external PLC (IN-OUT signals to recall
working programs)
local and /or remote management over LAN and
WI-FI LAN

SI-STAR WORKING MODES (4.0 ready)

Stand-alone (no PC/tablet required)
local and /or remote over LAN - WI-FI LAN
program recall by external PLC
(in/out digital connections)

SI-STAR Sinergo desktop soldering robot

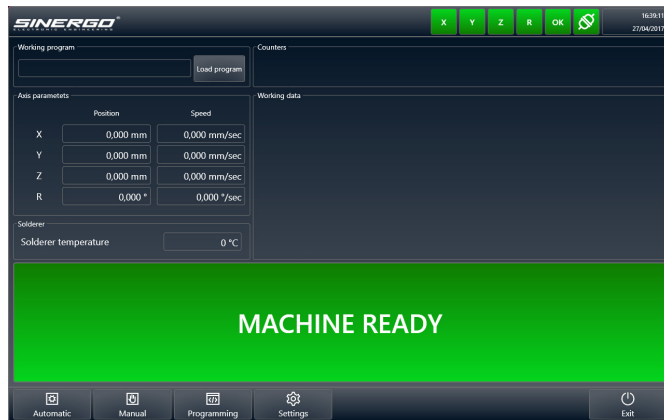

PROGRAMMING

Human Machine Interface software by Sinergo (WIN 7 - 10)
 English default. More languages upon request
 HW OPTION: 10" tablet or Notebook (WIN 7- 10)
 255 working programs (200 points each one) memory on board.
 Infinite numbers of working programs available over LAN.
 Many functions available: single point, step by step, sliding soldering, skip to, pre-tinning functions, programmable tip cleaning, ...
 Local & remote program managing and recalling.
 Password access.

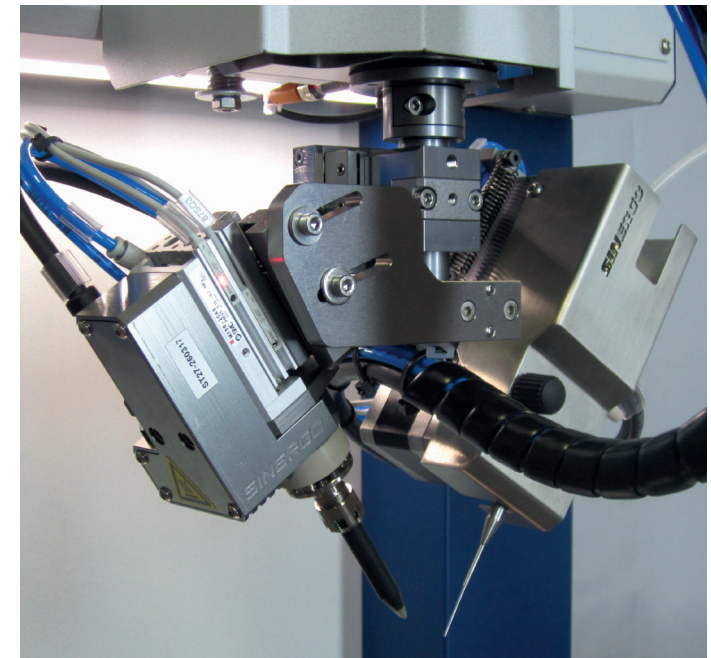

SOLDERING HEAD

Made by light alloy and stainless steel.
 Made by 3D CAD + CAM CNC machining
 Adjustable geometries for hot iron and tin wire feeder
 Independent pneumatic slide moving hot iron and wire feeder

SI-PRO Sinergo hot iron 150W on adjustable damper
SI-DIF Sinergo precision tin wire feeder with encoder
SI-CLEAN Sinergo tip cleaner set.

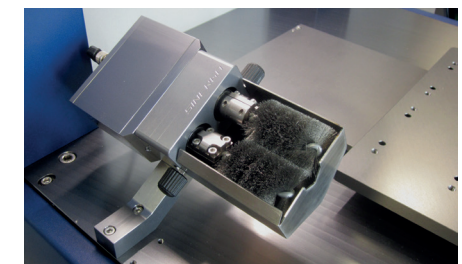

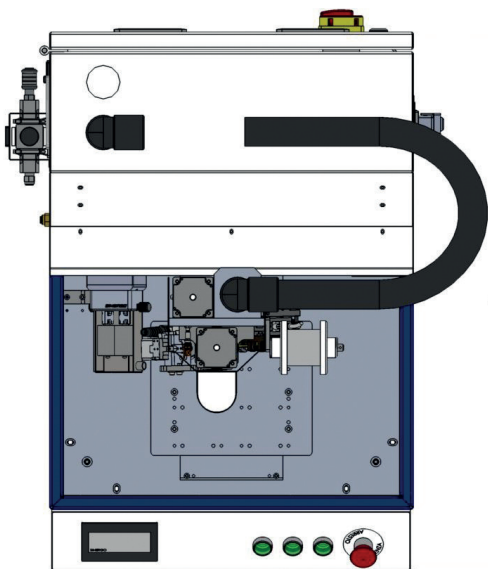
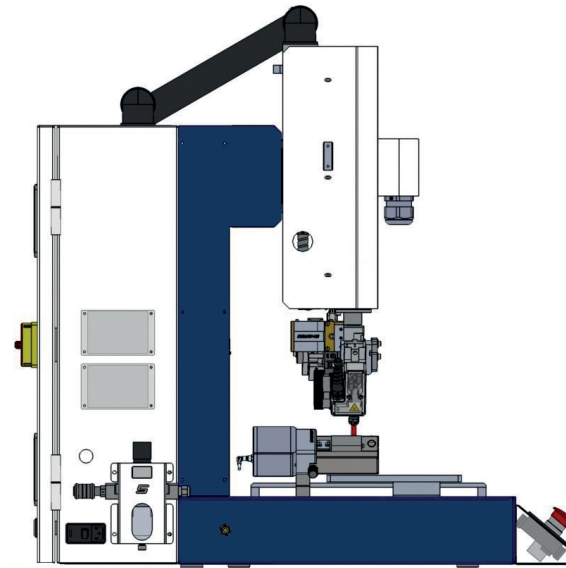
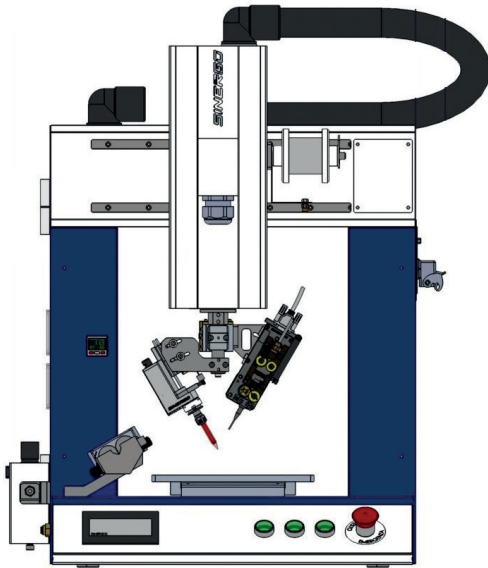

Width 650 mm + X stroke 100 mm
Depth 850 mm
Height 950 mm + Z stroke 120 mm
Weight 94 Kgs

Supply 1x230 Vac 50-60 Hz 16A socket
Power demand: 700 VA max
compressed air 6Kg/cm² connection
LAN socket
USB socket
WI FI access
“Safety chain circuit” socket
IN OUT digital signals socket

OPTIONS:
Soldering process study and optimization.
Dedicated tooling design and supply.
WIN 10 tablet
WIN 10 notebook